



# STAIRS

WMF PHASE 6

Jennifer Byrne 2026

## 2 Stairs

- What is the definition of a stairs?
- A stairs is a means of providing access from one floor level to another level. (A series of steps from one floor level to the next floor level in either one or more flights)
- What are the Requirements of a stairs?
- Ergonomically and structurally sound.
- Durable.
- Easy to navigate.
- Aesthetically pleasing.
- [Technical Guidance Documents: TGD](#)



### 3 Stairs Label The Parts

- Handrail
- Newel post
- String
- Baluster
- Step
- Tread
- Riser

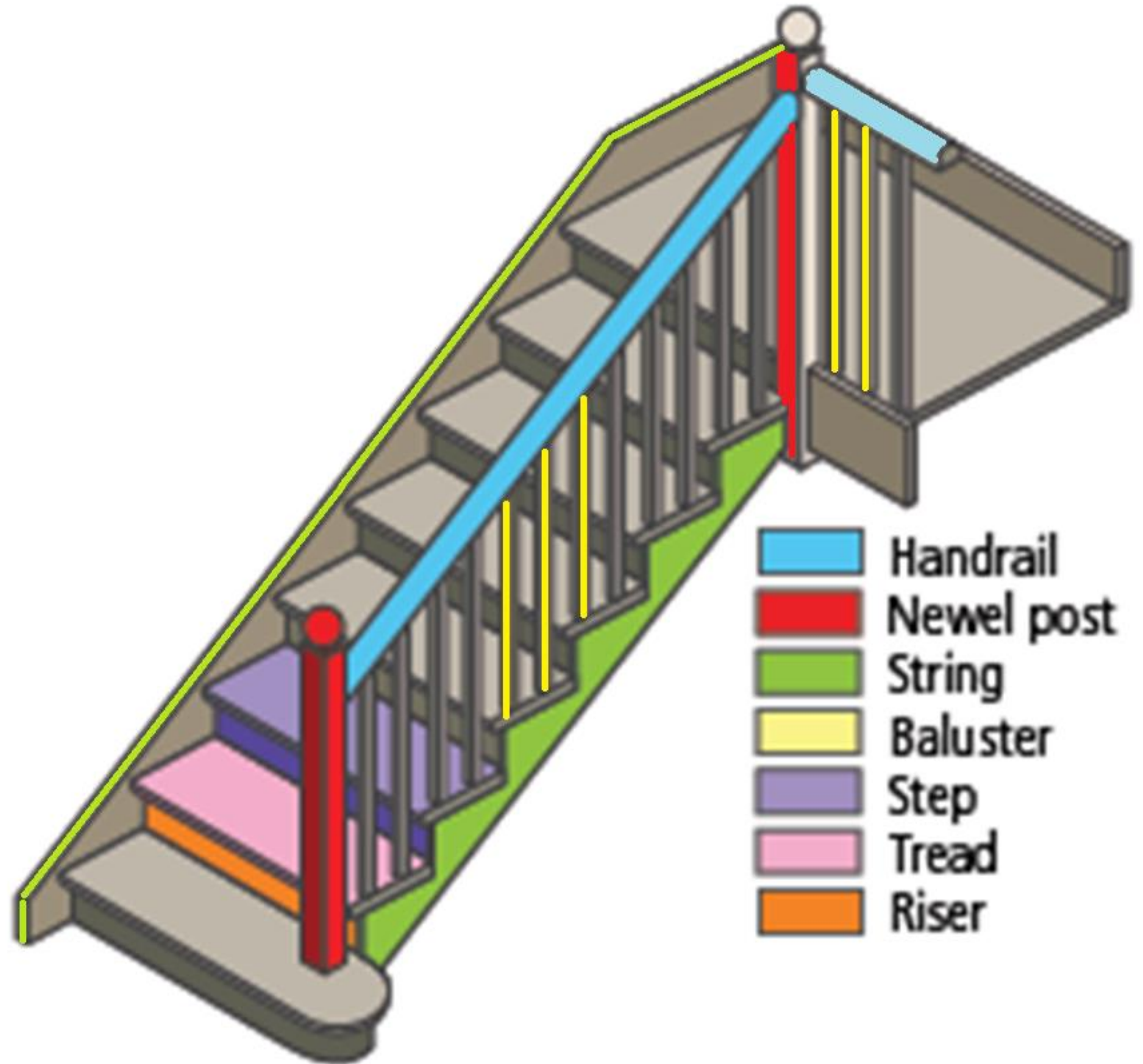

# 4

## Timber Stairs

- Name the parts sheet answers.

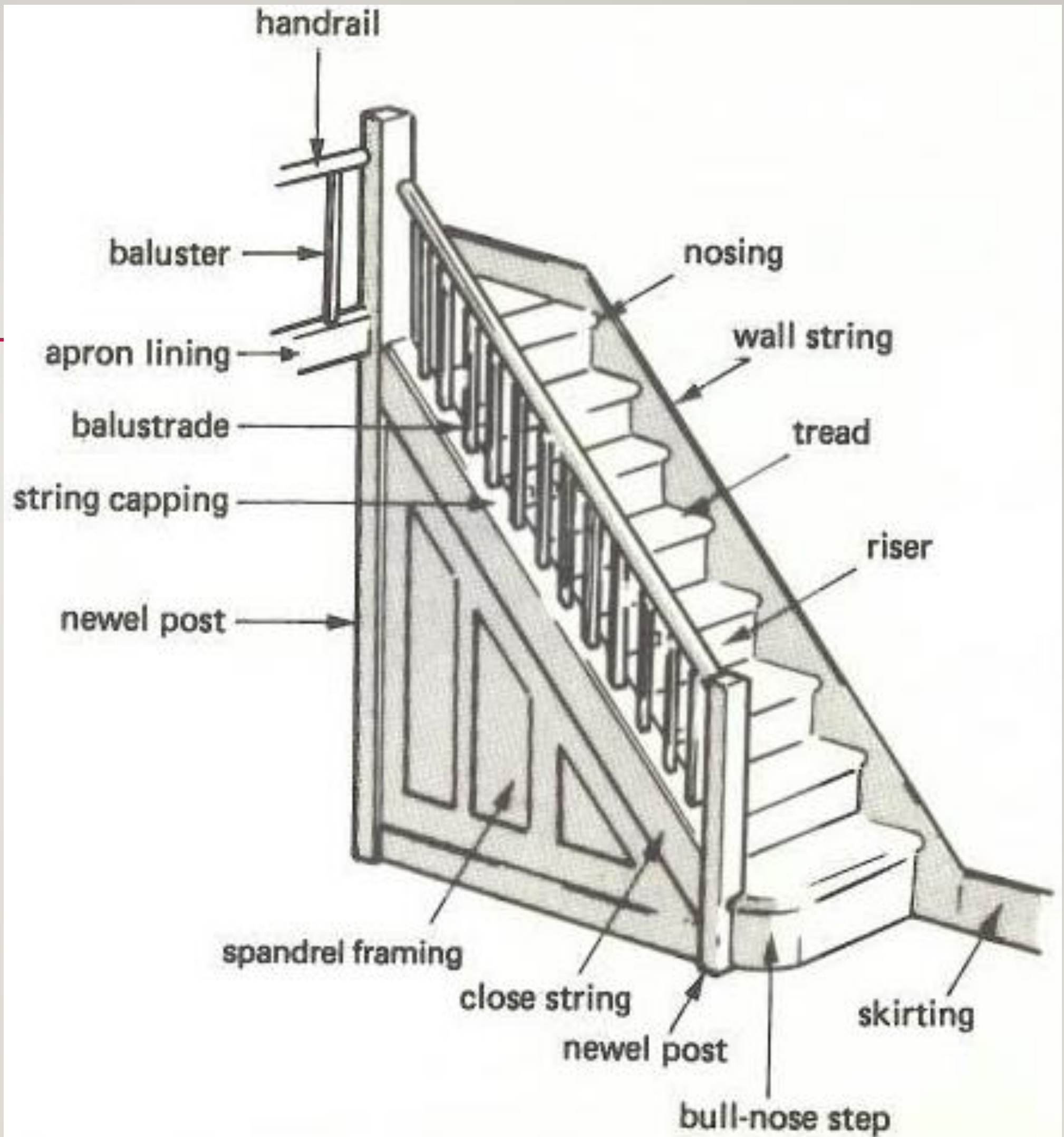
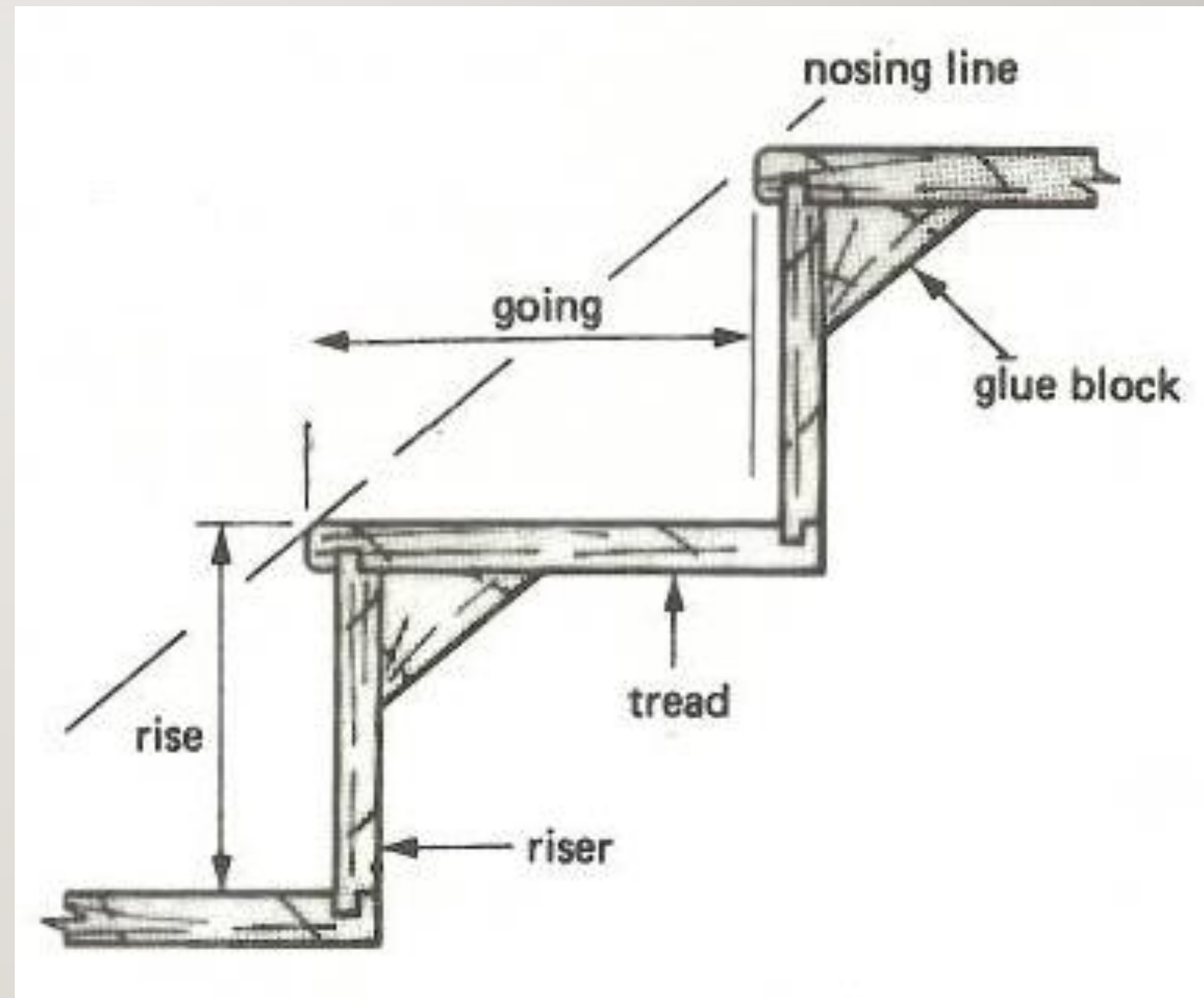

Figure 208 *Stairway terminology*

## 5 Stair Terminology

---

- **Stairwell:** The opening in the upper floor, or space in which stairs and landings are housed.
- **Tread:** The horizontal member of the step (where the foot is placed).
- **Riser:** The vertical member between two consecutive treads.
- **Nosing:** The exposed edge of a tread, it usually projects over the riser and has a splayed or rounded edge.
- **Step:** Riser plus tread.
- **Going:** The horizontal distance between two consecutive risers.
- **Rise:** The vertical distance between two consecutive treads.



## 6 Stair Terminology

- **Overall rise:** The vertical distance from one floor level to the next floor level.
- **Overall going:** The horizontal distance from the face of the first riser to the face of the last riser.
- **NOTE:** There will always be one more rise than going in a flight
- **Flight:** A series of steps without a landing.

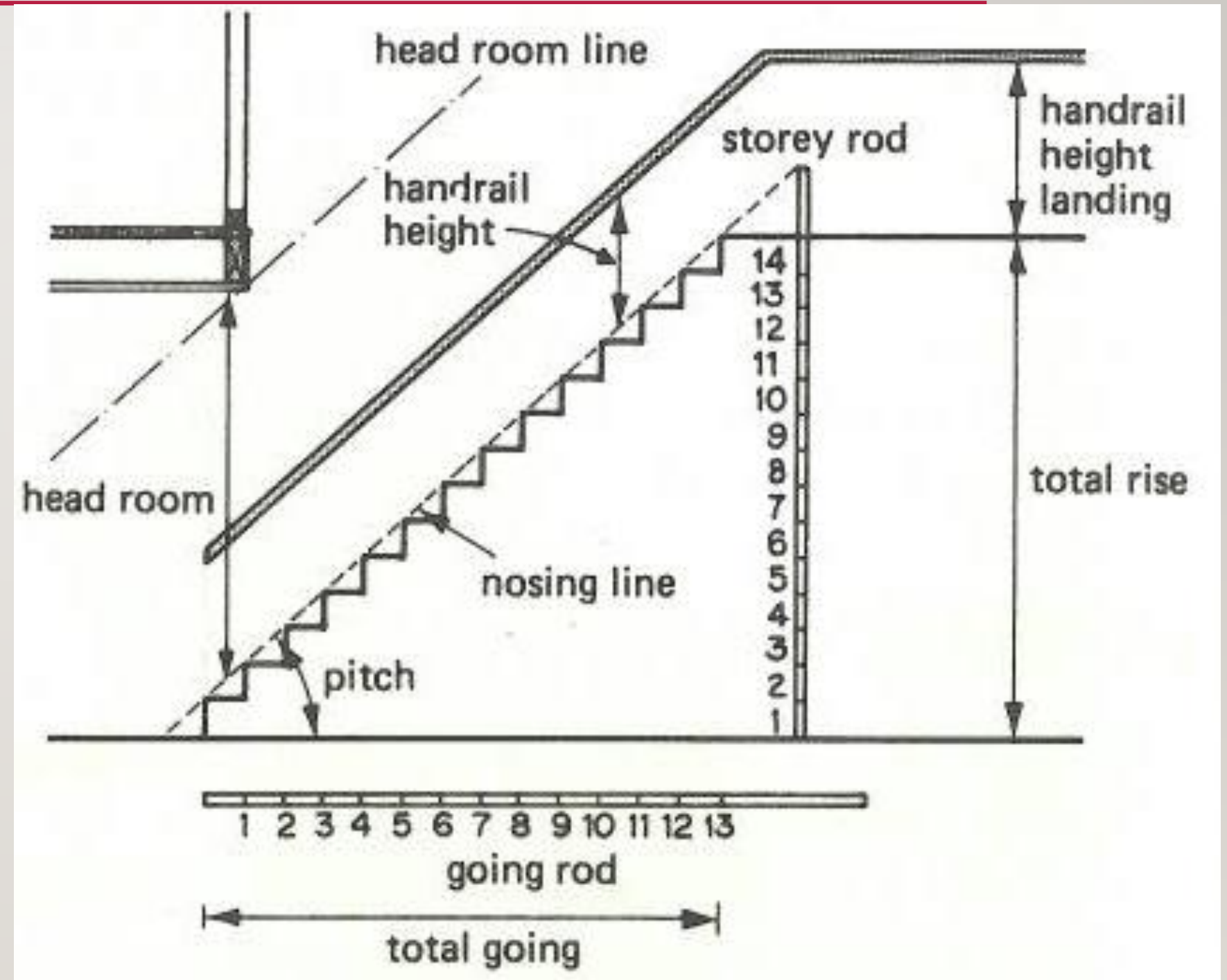

# 7 Stair Terminology

---

- **Strings:** The members carrying the ends of the steps (which are usually housed into the strings and secured by wedges). They are called wall or outer strings according to their position.
- **Newel:** The post at the junction of a flight of stairs with a landing or at the lower end of a string.
- **Handrail:** Protecting member, usually parallel to the string and spanning between newels, can also be attached to a wall, above and parallel to a wall string.
- **Pitch line:** A line connecting the junctions (at the nosing) of all the risers and treads in any one flight.
- **Balusters:** The vertical members between string and handrail, together with handrail and newels they form the balustrade.



# 8 Stair Terminology

- **Nosing line:** A line connecting the nosings of all the treads in any one flight.
- **Headroom:** The clear distance, (measured vertically above the nosing line) between the nosing line and any ceiling or bulkhead above it.

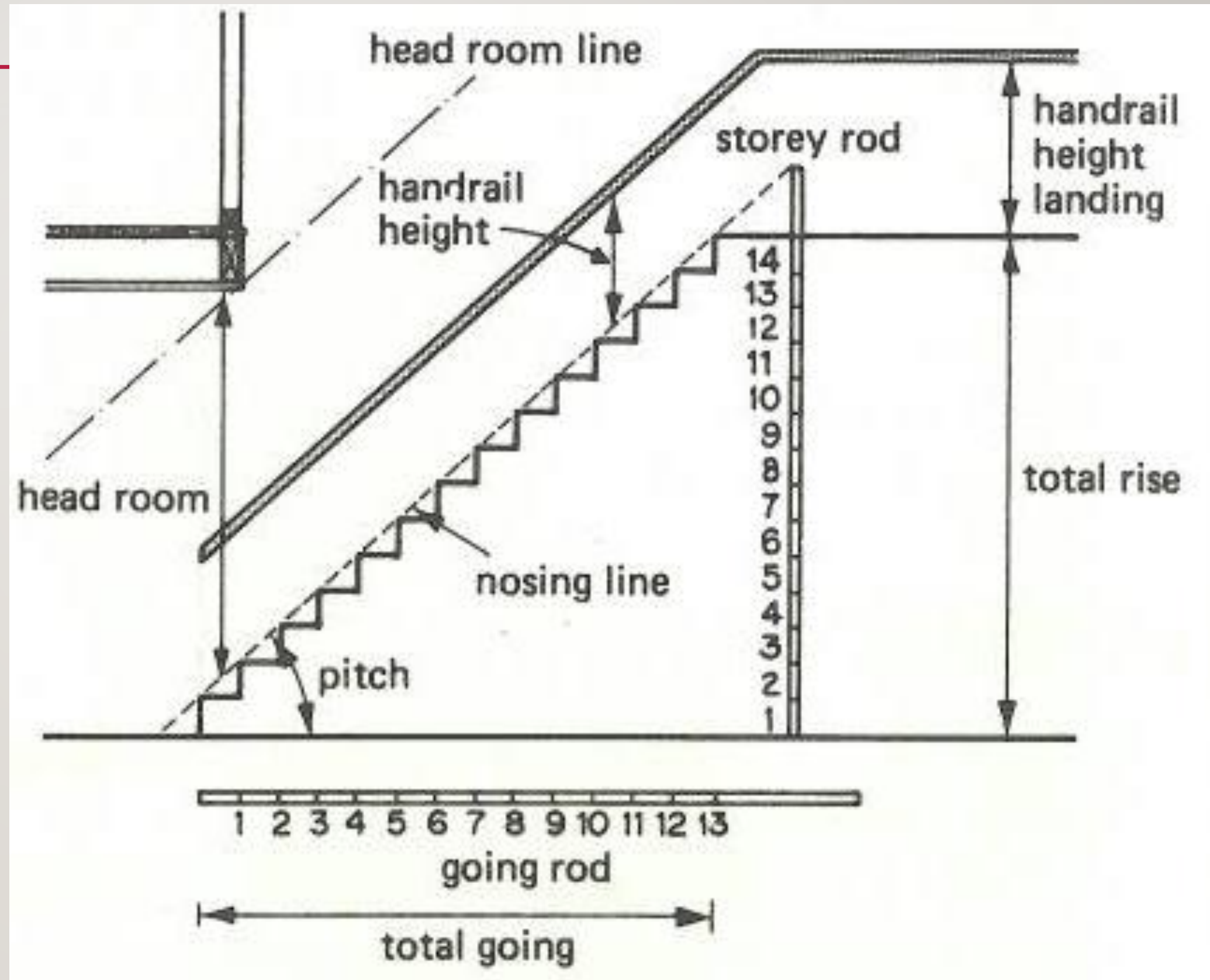

# 9 Stair Types

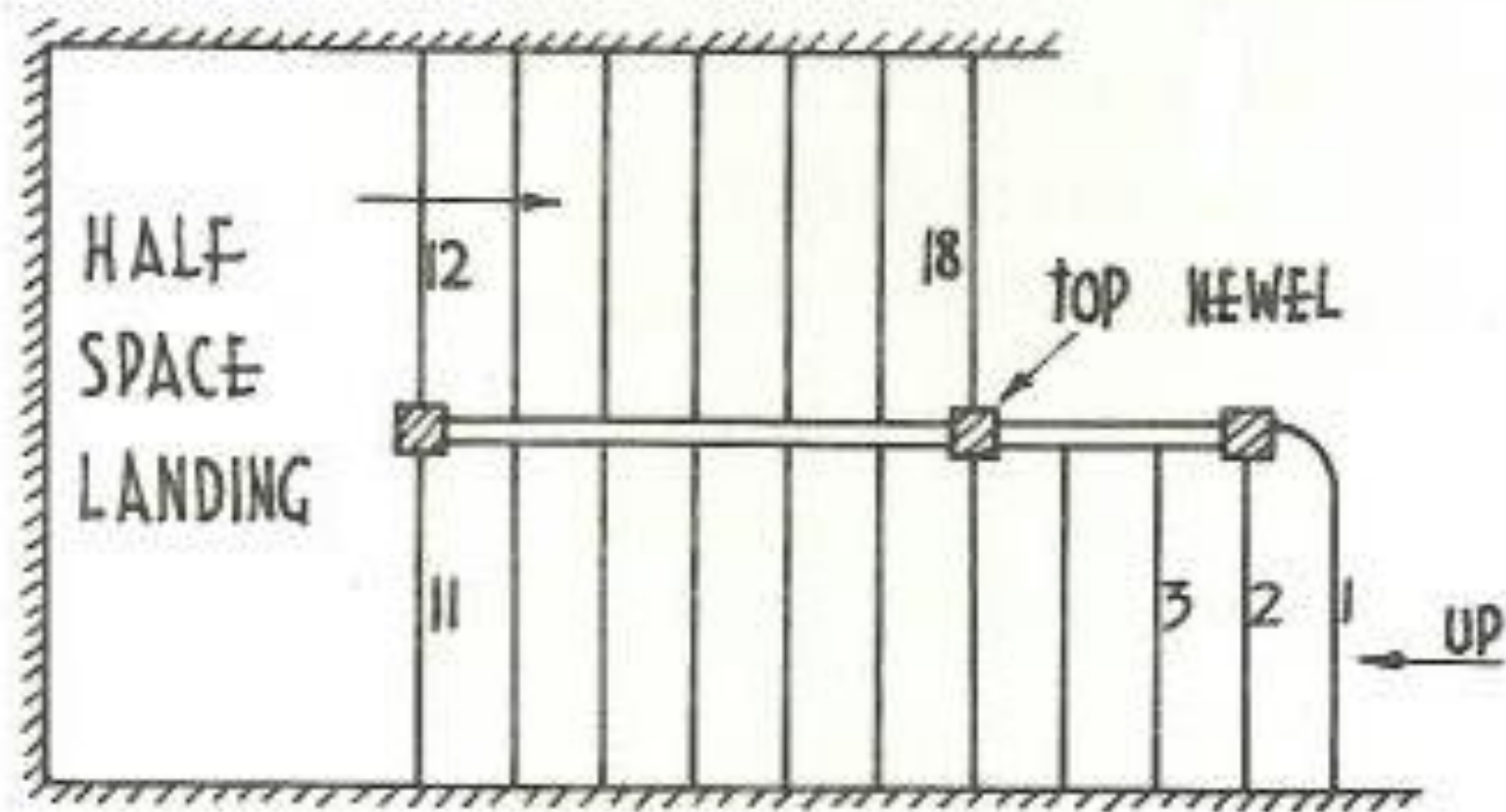

Dog Leg Stairs

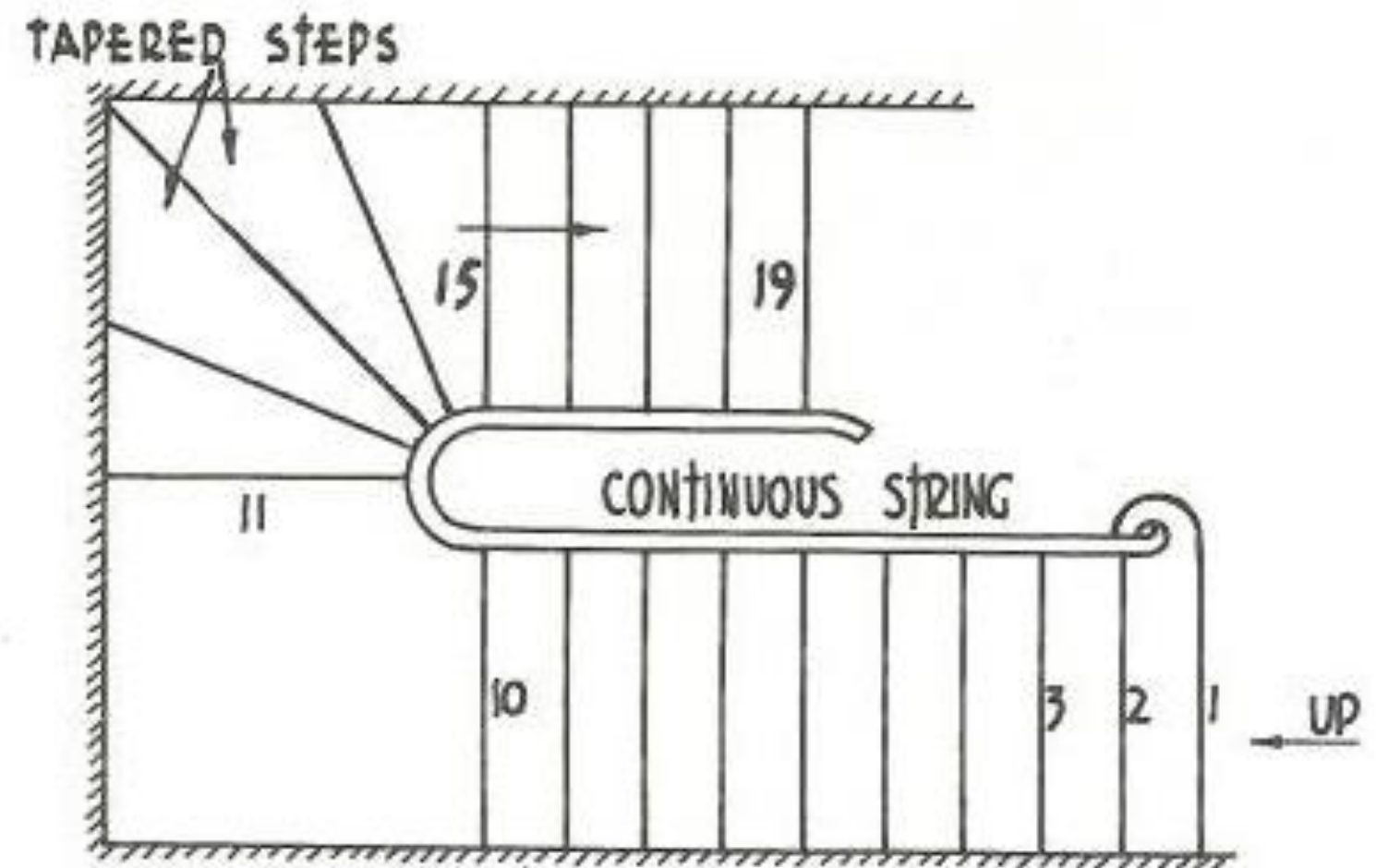
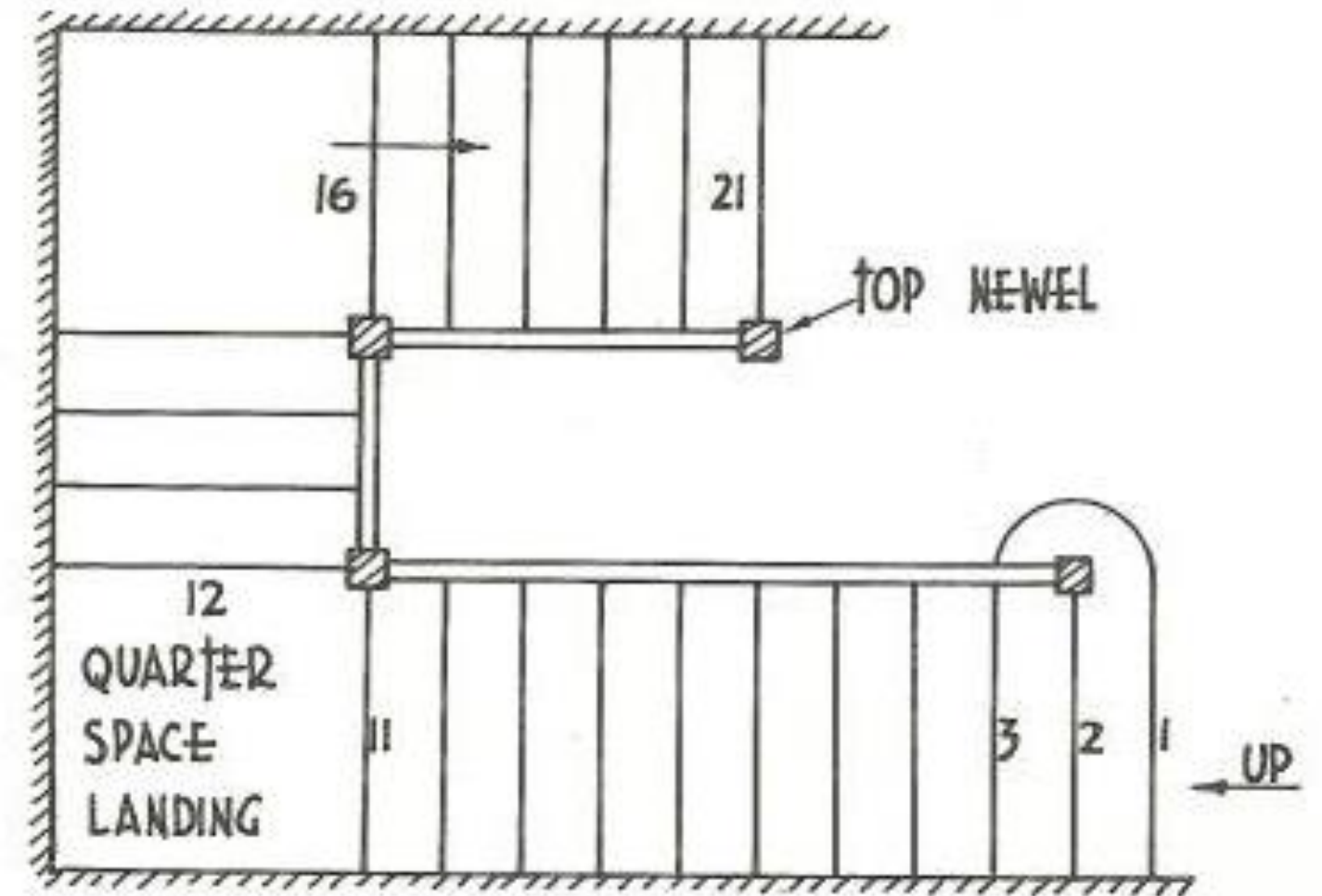

# 10 Stair Types

- Straight Stairs.
- Quarter Turn Stairs.
- Dog Leg Stairs.
- Winder Stairs.
- Spiral Stairs.
- Curved Stairs.
- Cantilever Stairs.
- Split Staircase (Bifurcated)

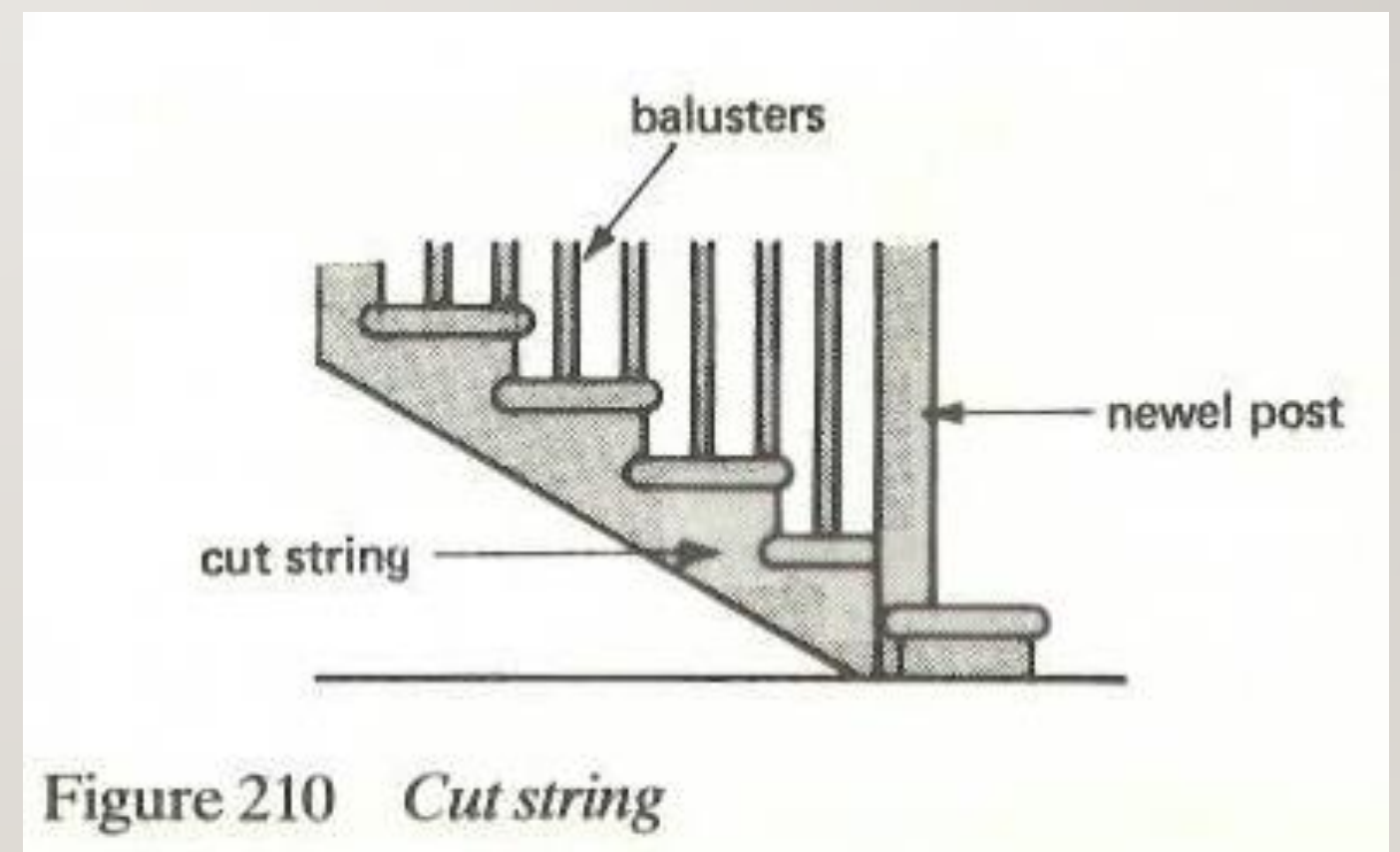
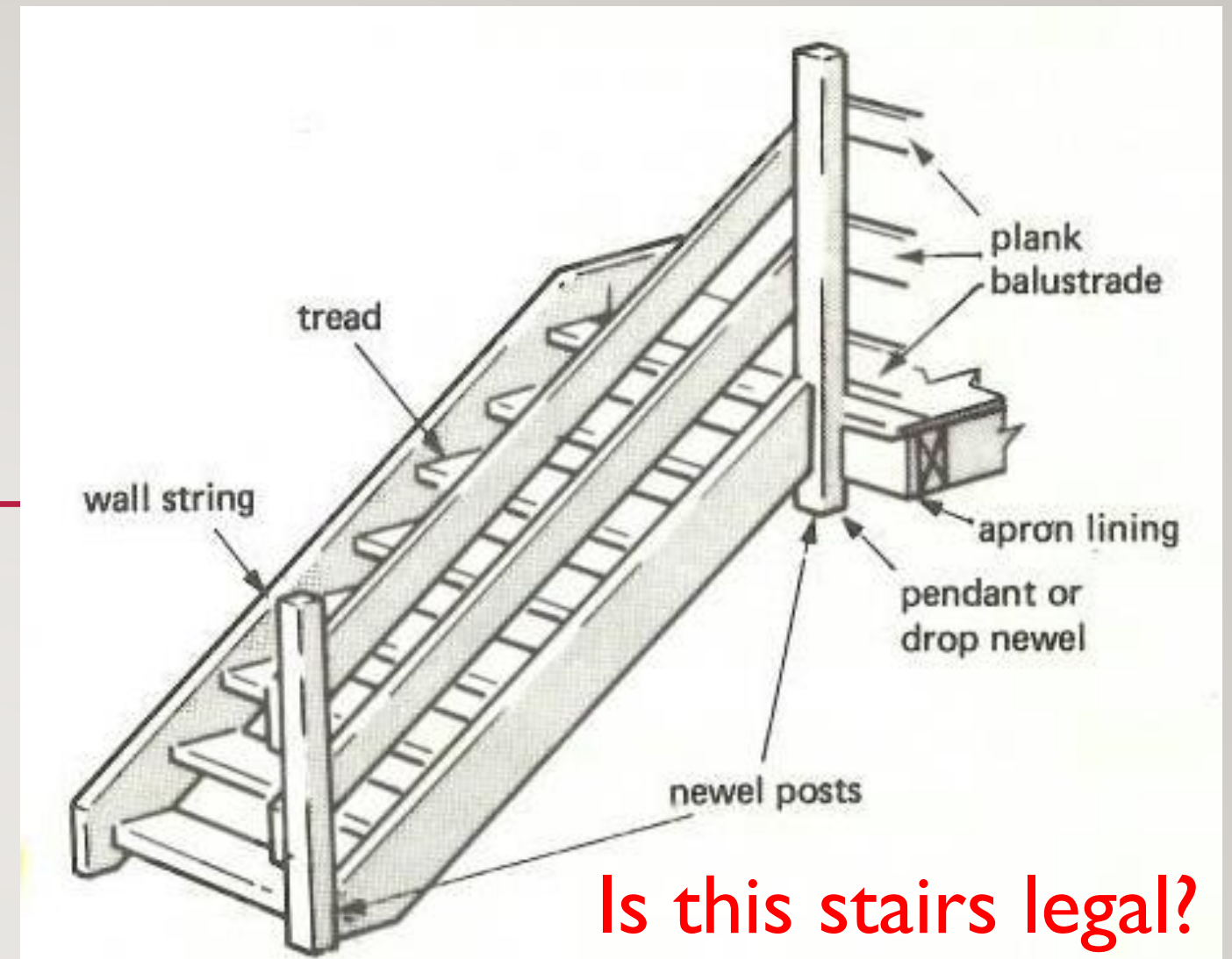

**What is the difference between a closed string and a cut string?**

# || Straight Wooden Stairs

---



# 12 Quarter Turn Stairs



# 13 Dog Leg Stairs

---

- **Layout:** Two straight flights with no open space between them in the plan view.
- **Landing:** A platform connects the first flight to the second, reversing the direction by 180 degrees.
- **Appearance:** Looks like a dog's leg in elevation view.
- **Space Efficiency:** Excellent for utilising compact or rectangular areas.
- **Privacy:** Offers more privacy between floors compared to open-well stairs



# 14 Open Well Stairs

---

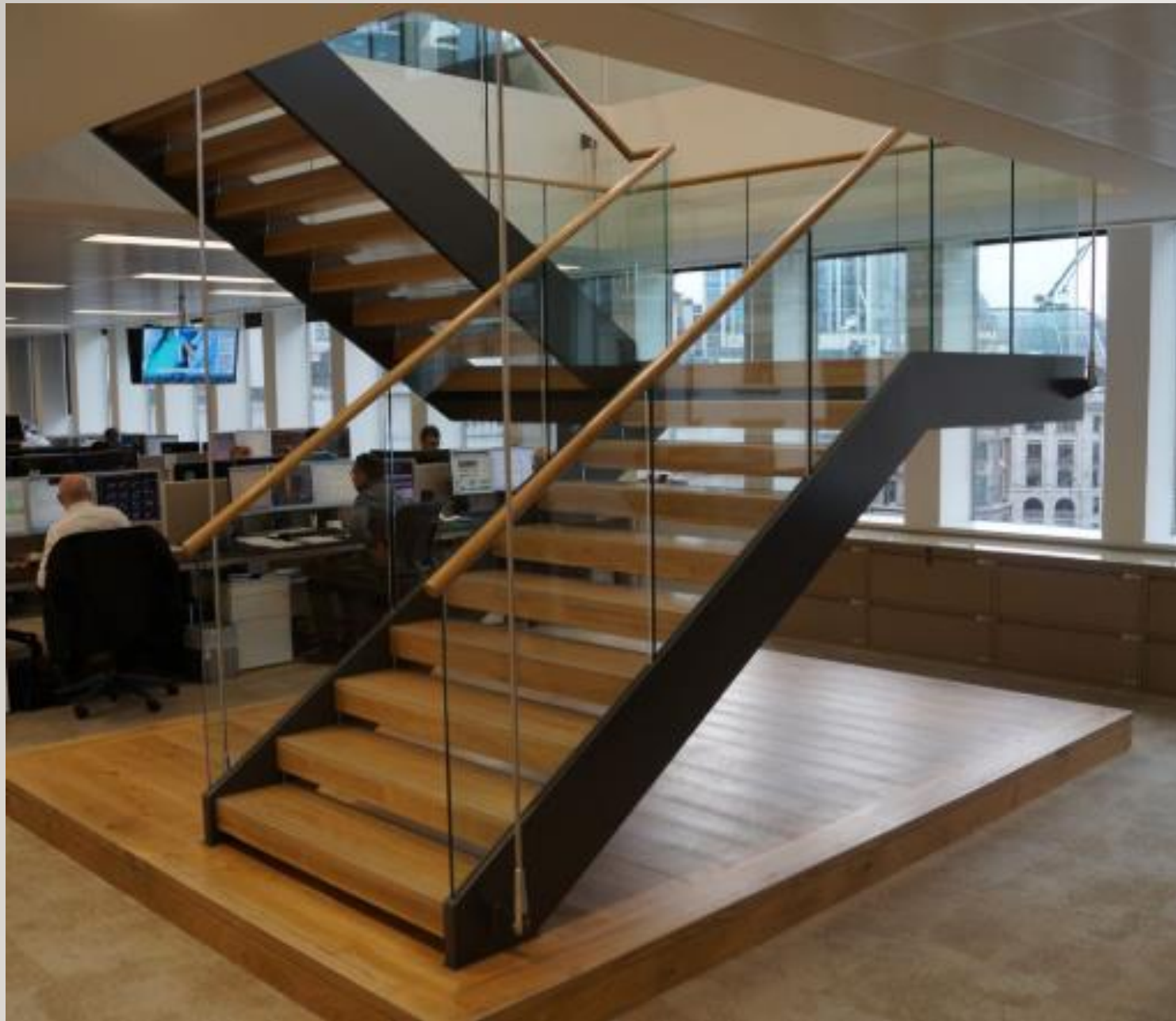

15

# Winder Stairs

---

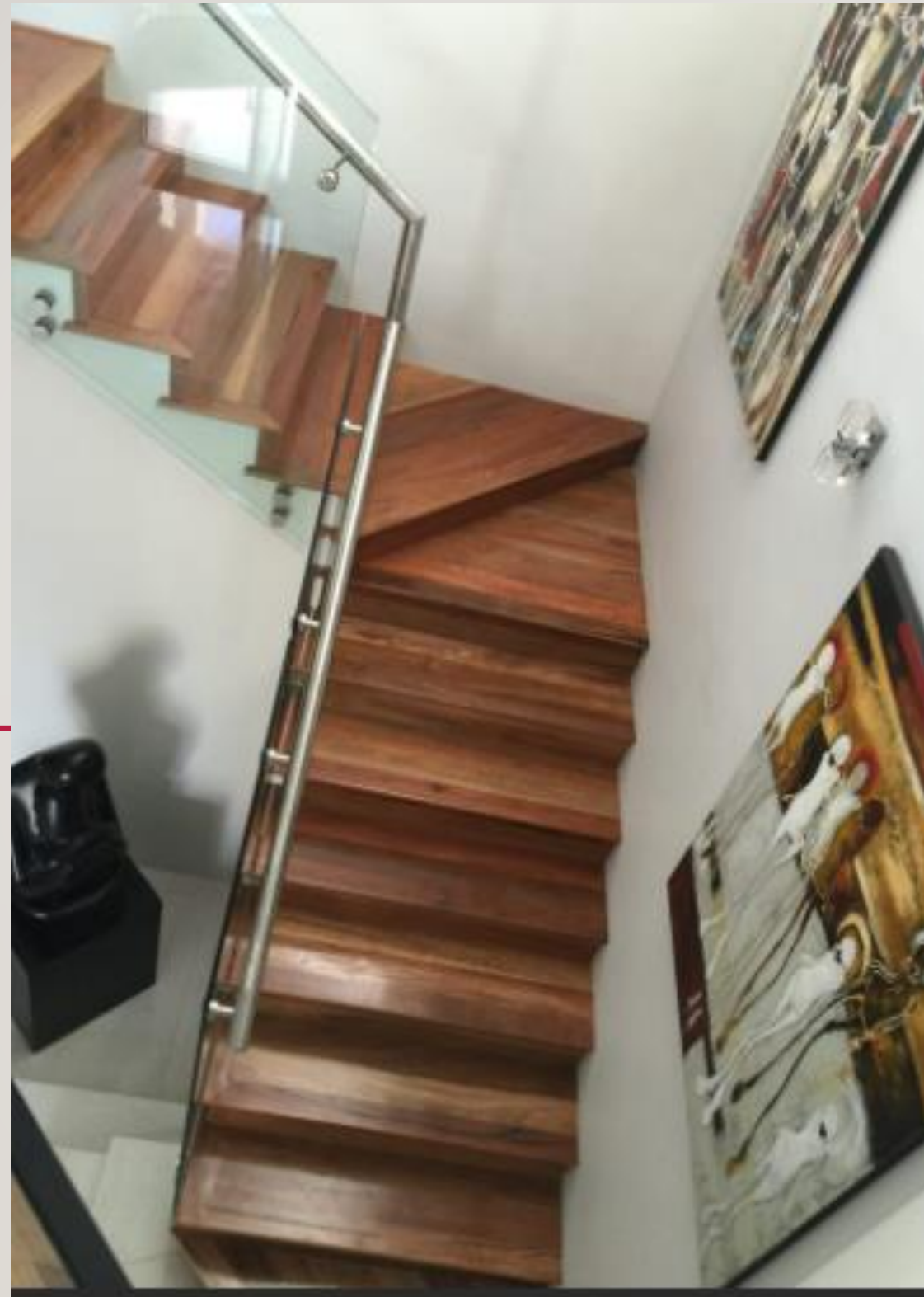

# 16 Spiral Stairs & Geometric Stairs



# 17 Curved Stairs or Geometrical Stairs

---



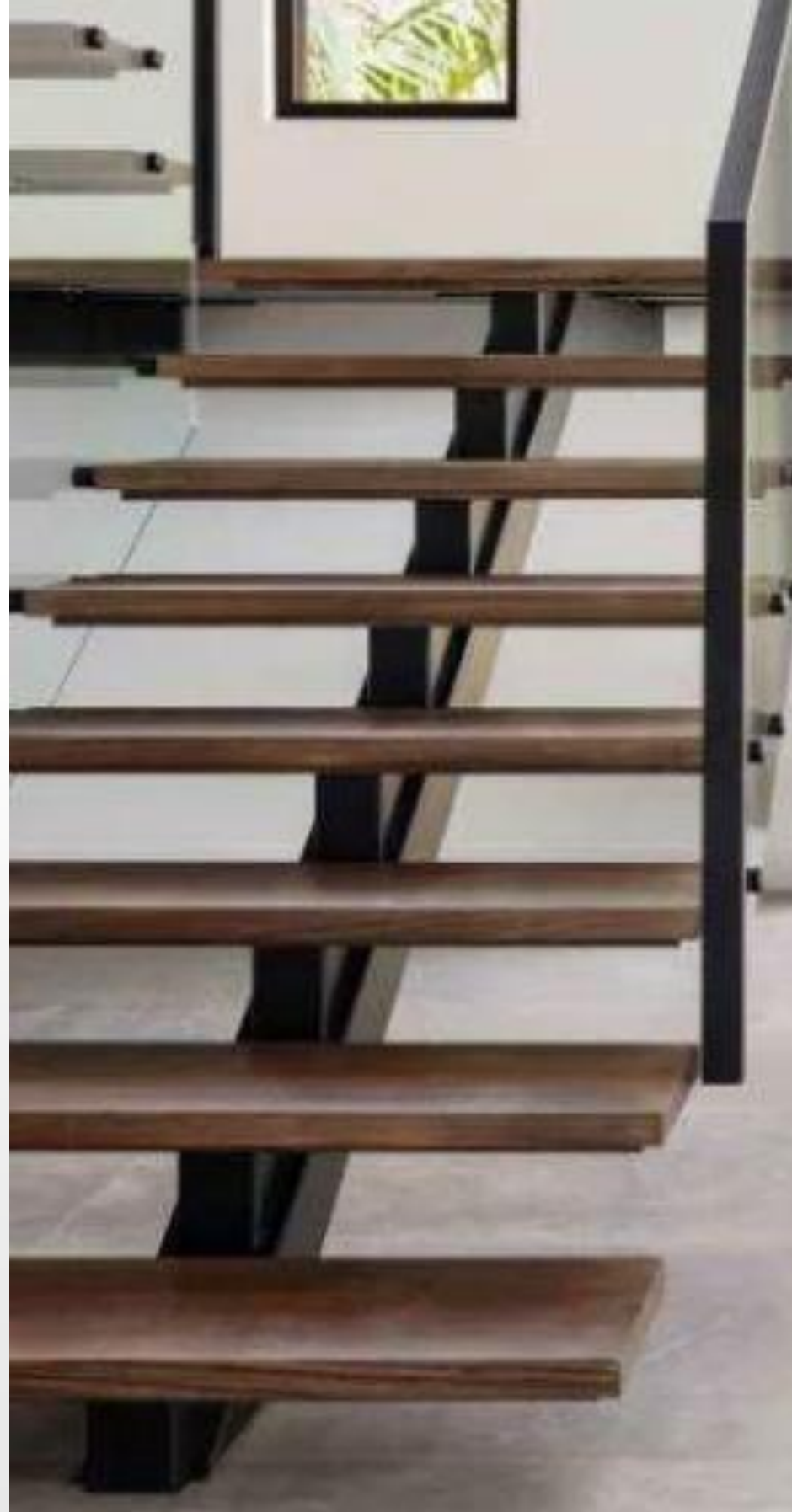

## Cantilever Stairs

---

Must conform to regulations

# 19 Cantilever Stairs



Regulations?



## Split Staircase (Bifurcated) Stairs 20

A bifurcated staircase, also known as a **split staircase**, starts with a single, wide flight of stairs that splits at a landing into two narrower flights, typically branching in opposite directions to reach the same upper level



## 21 Period Stairs

---



18<sup>th</sup> Century Georgian Staircase



Victorian Staircase



Grand House Victorian Staircase



# 22 Ornate Stairs

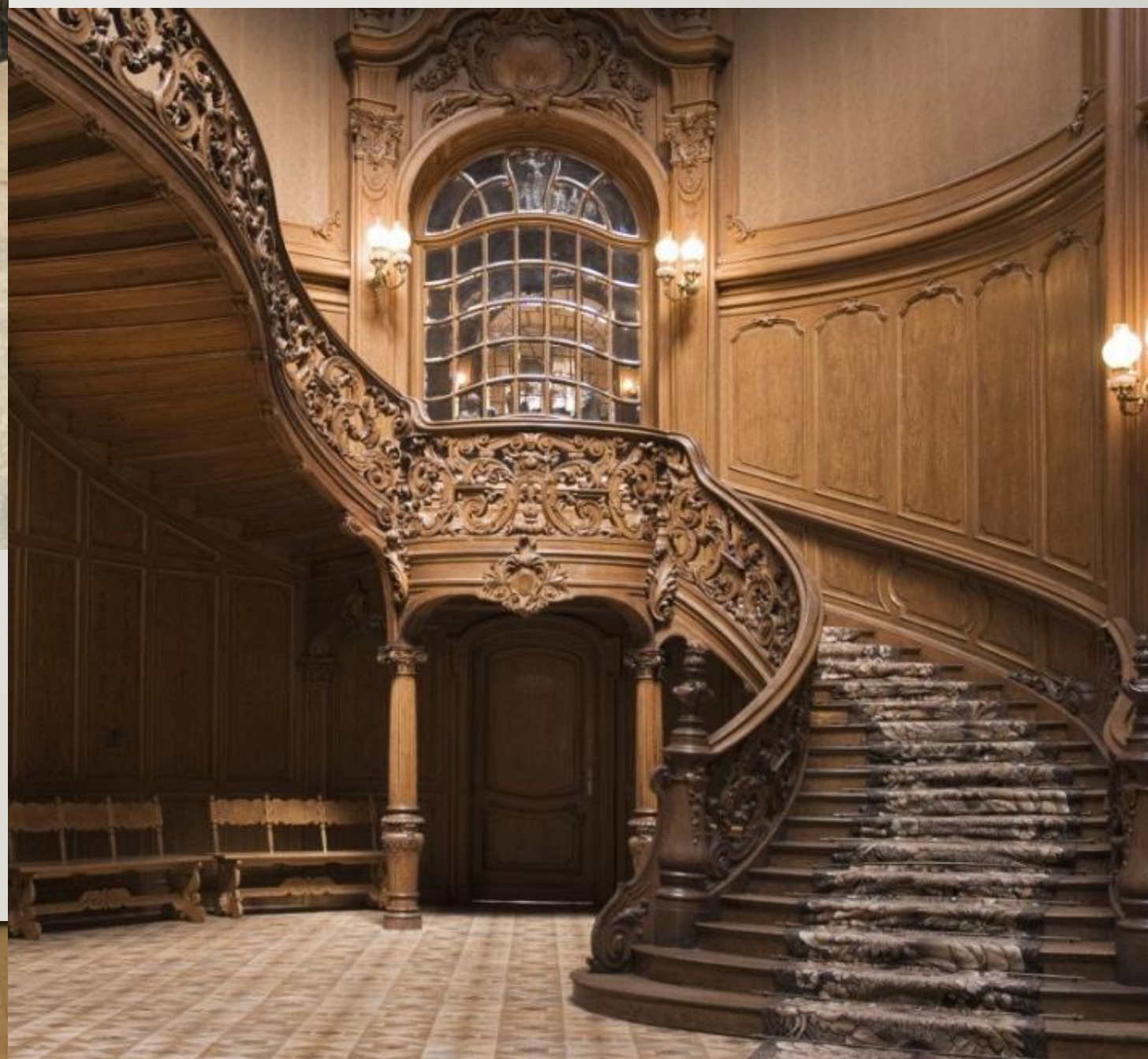

## 23 Witches Stairs



Alternate tread stairs in residential homes are likely a space-saving method, though they are usually only approved for locations with access to attics.

